

# R8051XC2\_ISS

Instruction Set Simulator  
for the World's Fastest 8051 Microcontroller

## MAJOR FEATURES

- ◆ Pure C++ language + SystemC TLM 2.0 wrappers
- ◆ Implemented unified debugger interface
- ◆ Co-simulation support
- ◆ Complex TLM infrastructure

## PERFORMANCE

As the **R8051XC2\_ISS** is written in pure C++ with external TLM 2.0 wrappers, it offers high instruction processing rate.

Only native C++ types were used inside ISS module to provide high simulation speed. Despite that, the R8051XC2\_ISS is fully interpretive instruction set simulator that gains highest possible flexibility level.

At 1.73 Intel™ processor it is capable of running at approximately 5.7M instructions per second (in pure PV mode, without SystemC thread switching).

## OVERVIEW

The **R8051XC2\_ISS** is an instruction set simulator (ISS) that implements functionality of R8051XC2 core. High speed (due to pure C++ implementation) and high flexibility (thanks to SystemC TLM 2.0 wrappers) make it suitable either as a base for R8051XC2-compatible simulator / software debugger (eg. in 3rd party IDE software), or in SystemC environment as a high speed replacement for RTL core, mainly in embedded software design and verification process.

Full MCS51-family instruction set is implemented and all external interfaces (including peripheral set ones) are designed to ensure fast and error-free integration with environment and CPU compiler tools; running and debugging embedded software is also easy thanks to object-oriented, easy-to-use debug interface with additional module, that allows using OCDS functionality.

## BLOCK DIAGRAM

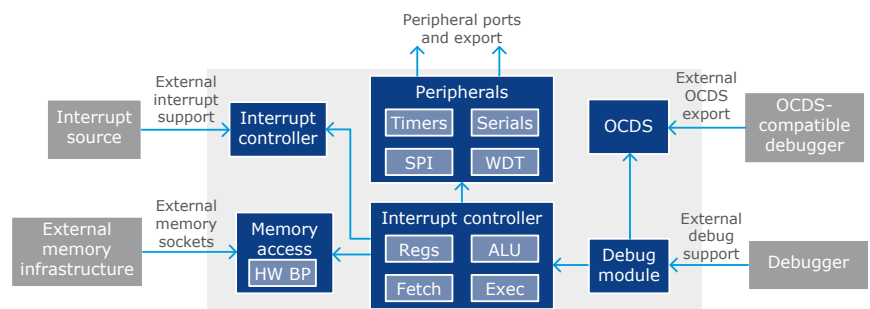

# R8051XC2\_ISS

## CONFIGURABILITY

**R8051XC2\_ISS** can be configured the way the R8051XC2 is; all peripherals can be affected by the configuration.

Configuration is applied dynamically by providing descriptor structure to **R8051XC2\_ISS** constructor, so no source recompilation is needed.

## RELATED PRODUCTS

**R8051XC2** - the world's fastest and most configurable 8051 microcontroller. It runs 12.1 times faster than the original Intel™ 80C51 and is available in 7 predefined configurations.

## BENEFITS

- ◆ High simulation speed
- ◆ Only C++ compiler needed
- ◆ Easy integration with TLM2 environment
- ◆ Easy and dynamic configuration

## APPLICATIONS

- ◆ Embedded software development and verification
- ◆ Debug module in 3rd party IDE software
- ◆ Co-simulation in RTL environment
- ◆ Complex CPU-based SOCs
- ◆ Performance estimation

## STANDARD DELIVERABLES

- ◆ Source code of the **R8051XC2\_ISS**
- ◆ TLM infrastructure including described interfaces and modules
- ◆ R8051XC2 co-simulation support (transactors and scripts)
- ◆ Full documentation
- ◆ Set of compilation / simulation scripts (MTI)
- ◆ 30 days of technical support
- ◆ 90 days of warranty against defects

## DELIVERY OPTIONS

- ◆ C++ / SystemC source code
- ◆ Precompiled libraries



For more information on our IP portfolio visit [www.evatronix.com/ip](http://www.evatronix.com/ip)



### EVATRONIX SA

Przybyły 2, 43-300 Bielsko-Biała, Poland  
T: +48 33 499 59 15  
F: +48 33 499 59 18

[info@evatronix.com](mailto:info@evatronix.com)  
[www.evatronix.com/ip](http://www.evatronix.com/ip)